



AIR CONDITIONING



REFRIGERATION



HEATING



# hi-flow 0.5L

## CONDENSATE REMOVAL PUMP



This compact yet powerful pump has the smallest footprint of all our centrifugal tank pumps. Offering extra placement flexibility when space is limited.



300L/h max. flow



3.2m max. rec. head (flow rate 50L/h)

### KEY FEATURES

- Plug & play
- Non return valve
- Wall or floor mounted

### SUITABILITY

- Up to 240kW / 818,000Btu/h
- Ducted units; Floor standing & Chassis units; Cassette units; Refrigerated units / cold store

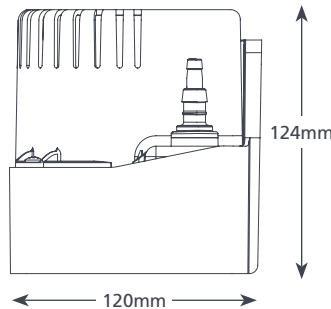
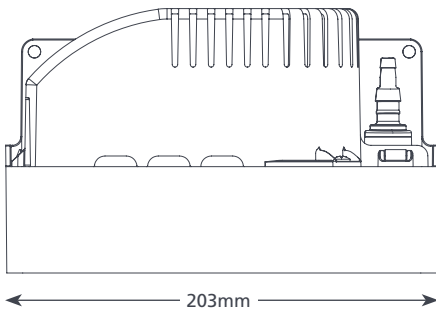

### HI-FLOW 0.5L SPECIFICATIONS

Max. flow	300L/h @ 0 head
Max. rec. head	3.2m
Tank capacity	0.5L
Sound level@1m	51dB(A)
Power supply	230V AC 50-60Hz 0.45A*
Rated	Continuously
Class	I appliance
Max. unit output	240kW / 818,000Btu/h
Max. water temp	40°C / 104°F
Inlet/outlet	x2 27mm in, 6-10mm out
IP Protection	IPX0
Safety switch	3.0A Normally closed
Thermal protection	✓
Fully potted	n/a
Self priming	n/a

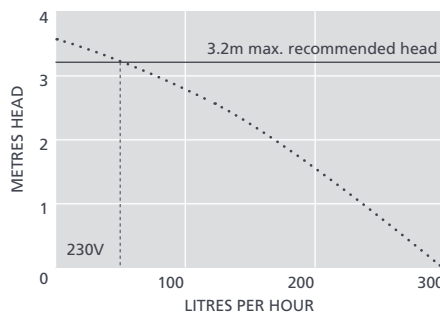

### SUGGESTED XTRA ACCESSORIES

Description	Part No.
Tank pump connector 16mm-21mm	FP2011
Tube To Soil Stack Adaptor	FP2038
Vinyl Tube Braided 1/4" (6mm)	AX5110

**Xtra** For more installation accessories take a look at our Aspen Xtra range

### HI-FLOW 0.5L OPTIONS

Hi-flow 0.5L FP1194/2

\* Other voltages available

### IN THE BOX

Hi-flow 0.5L pump • 2m Plug & play power cable • Fixing kit • Install manual

Download manual at [aspenspumps.com](http://aspenspumps.com)

Information correct at time of going to press.



[aspenspumps.com](http://aspenspumps.com)

+44 (0)1323 848842

[sales@aspenspumps.com](mailto:sales@aspenspumps.com)

Making life easier for the installer